



More Precision

interferoMETER // Ultra-precise white light interferometers



High precision white light interferometers interferoMETER

The innovative white light interferometers from Micro-Epsilon set a benchmark in high-precision distance and thickness measurements. These sensors enable stable measurement results with sub-nanometer resolution, offering a comparatively large measuring range and offset distance.

Micro-Epsilon interferometers work differently than laser interferometers with polychromatic white light. The integrated light source uses an extended wavelength spectrum instead of a defined wavelength. Thus, significantly more information is available for the evaluation of the superposition from transmitted and received wavelengths.

This results in advantages for the measurement:

- Absolute measurements with highest precision, even with moving targets
- Wide range of applications: Distance measurement, multi-peak measurement of several layers and thickness measurement of thin layers as well
- Maximum signal stability for industry, machine building or laboratory as well as in the semiconductor sector and vacuum

Maximum signal stability for nanometer precision

Micro-Epsilon interferometers generate precise and stable measurement values. This allows processes to be precisely regulated.

Easy controller replacement

IMS5400 controllers are easily replaceable - no sensor dismantling or recalibration required



Distance-independent thickness measurements

The IMS5400-TH systems provide thickness values of individual layers up to 2.1 mm total thickness. The target can move freely in the operating range.

Unmatched precision

The IMS5400-DS and IMS5600-DS systems are used for absolute distance measurements. They provide highly precise measurement values which brings advantages for distance control and for profile measurements of moving objects.

Overview

interferoMETER

General information

Page

Unmatched precision for industrial series applications

4 - 6

Possible applications - the right system for every application

7

Application examples

8 - 9

System type

		Purpose	Resolution	Page
interferoMETER IMS5400-DS	For absolute distance measurement with nanometer resolution	Distance	< 1 nm	10 - 11
interferoMETER IMS5400-TH	For stable thickness measurement with submicron resolution	Thickness	< 1 nm	12 - 13
interferoMETER IMS5600-DS	For absolute distance measurement with subnanometer resolution	Distance	< 30 pm	14 - 15

Dimensions / Accessories

Page

Dimensions

16

Accessories

17 - 19

Unmatched precision in distance and thickness measurements

interferoMETER

While Micro-Epsilon white-light interferometers provide absolute measurement values, common laser interferometers are based on the principle of relative measurements. Accordingly, the IMS white light interferometers are known for stable and absolute measurements without prior referencing. This is particularly favorable in the case of signal interruptions caused, for example, by steps, holes or structured surfaces. After the signal interruption, you directly receive a measurement value, whereas laser interferometers must first be re-referenced. Thus, distance profiles of moving measuring objects can be reliably generated with high precision.

Laser:

Reference required, loses position after signal interruption

White light:

No reference, absolute measurement value before and after a signal interruption

Robustness and industrial suitability with unmatched precision

- Robust sensors: IP65
- Industrial-grade controllers: temperature stability, passive cooling, aluminum housing
- Flexible cables and diverse accessories
- Flexible integration via Ethernet, EtherCAT, PROFINET ¹⁾, EtherNet/IP ¹⁾
- Stable thickness measurement even with vibrations

¹⁾ with interface module



The interferoMETER IMS5400-TH is used for high-precision thickness monitoring of plastic films.

Precise and stable down to the last nanometer

- Linearity ± 10 nm
- Vacuum suitability
- Greatest possible precision with large offset distance and measuring range
- Small light spot $10 \mu\text{m}$
- Fast measurements up to 6 kHz

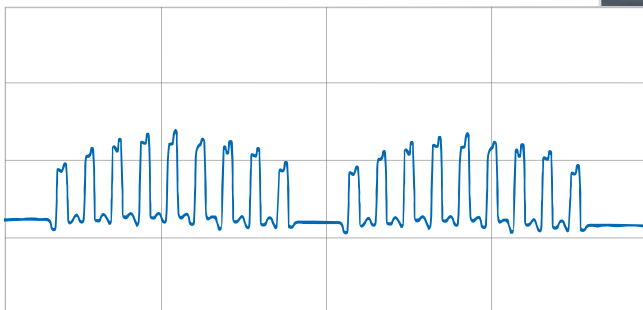

Structured wafer profile

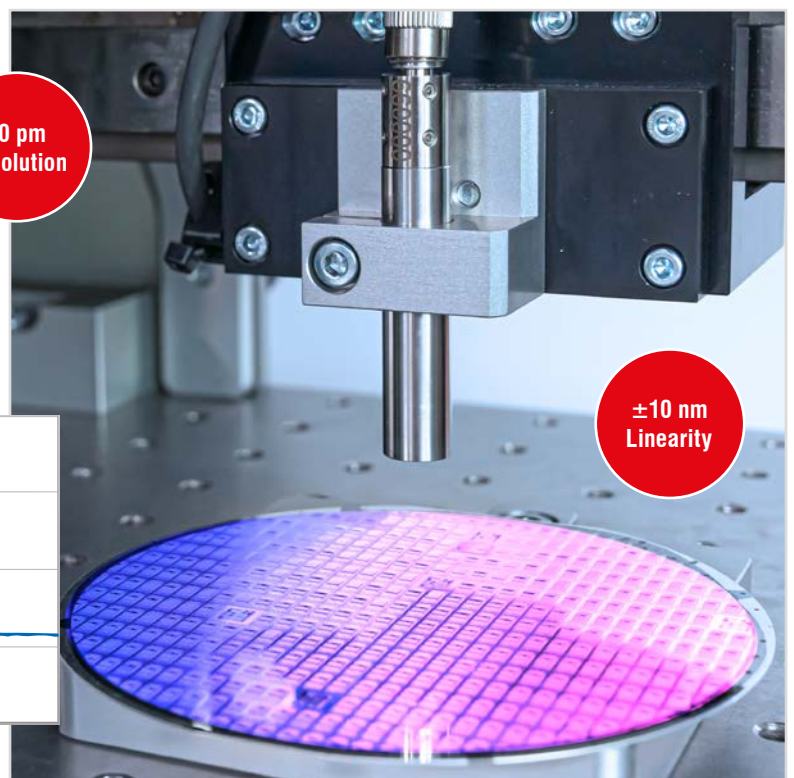

The IMS5600-DS offers highest precision in distance measurements. The absolute measurement allows for profiles of moving objects to be detected as well.

Powerful controllers

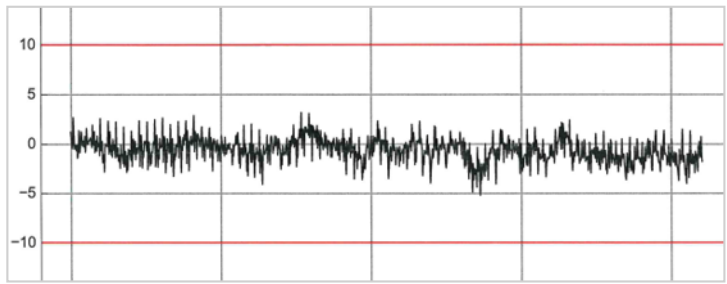

The InterferoMETERs are equipped with individual calibration protocols, documenting the precision achieved.



- Multi-peak models
- Intelligent signal processing
- Robust aluminum housing and durable SLED
- Extremely high temperature stability due to passive cooling
- Highest resolution < 30 pm
- Simple parameter set up via web interface
- Replaceable controller (IMS5400)

Analog

RS422

Ethernet

EtherCAT
Technology Group

PROFINET

EtherNet/IP

User-friendly web interface for easy operation

Due to a user-friendly web interface, no additional software is necessary to configure the controller and the sensors. The web interface is accessed via an Ethernet connection and allows quick and easy setting of e.g. averaging, measuring rate or presets and offers a material table for stable thickness measurements.



Presets for easy operation



Display for FFT signal

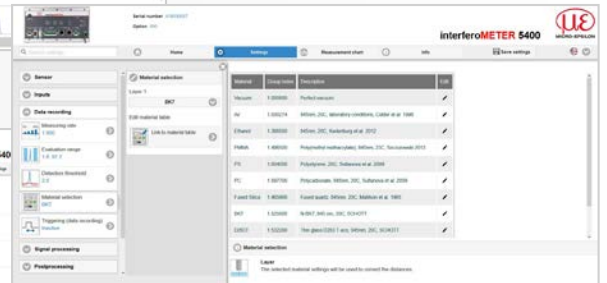

Materials table for thickness measurements

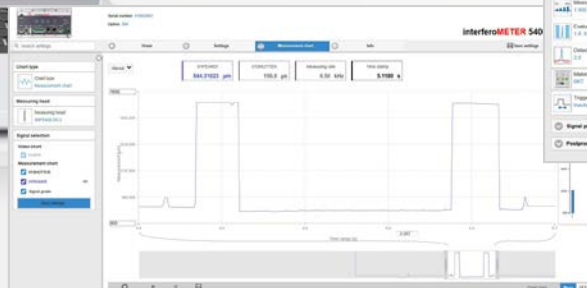

Measurement chart

Unmatched precision for industrial series applications

interferoMETER

Highest Z-axis resolution and small light spot

The sensors generate a small light spot that is almost constant over the entire measuring range. The light spot diameter allows the detection of small details such as structures on semiconductors and miniature electronic components.

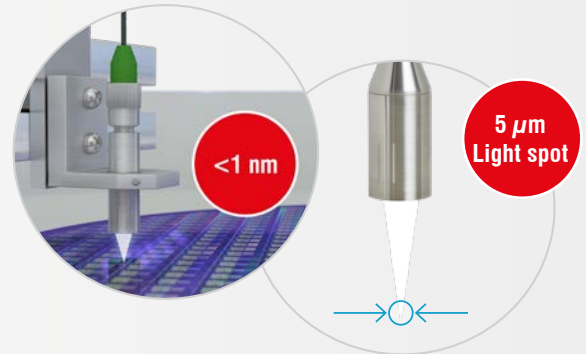

Pilot laser for exact visualization of the measuring point

White light interferometers work with infrared, non-visible light (approx. 840 nm wavelength), which means that the measurement position cannot be seen directly. To visualize the measuring position, Micro-Epsilon systems are equipped with a pilot laser which projects a light spot onto the measuring position. In addition, the pilot laser uses a patented method to provide feedback on the distance in addition to the measurement position. If the measuring object is at the correct distance and within the measuring range, a constant glow is emitted by the pilot laser. If the measuring object is outside the measuring range, the pilot laser flashes.

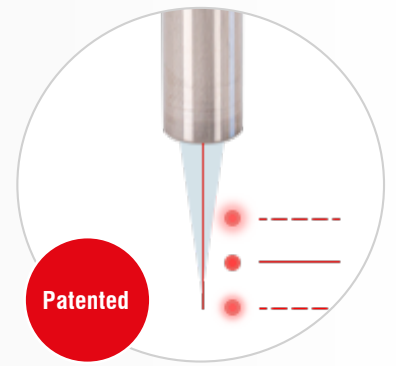

Robust design for industrial measurement tasks

Robust sensors and a controller enclosed in metal make the interferometer ideal for integration into automated production systems and machines. These compact sensors are extremely space-saving and can also be integrated in confined spaces. The controller is installed in the control cabinet via DIN rail mounting and provides very stable measurement results due to active temperature compensation and passive cooling.



Fast measurements on many surfaces



Glass



Metals



Films / coatings



Lenses

Possible applications - the right system for every application

interferoMETER



Absolute distance measurement

Distance measurement

Measuring objects: Optically dense as well as transparent objects

Models:

- IMS5400-DS19
- IMS5600-DS19
- IMS5400-DS19/VAC
- IMS5600-DS19/VAC



Multi-peak distance measurement

Max. 14 distance values and thickness calculation

Measuring objects: transparent objects (up to 840 nm)

Models:

- IMS5400MP-DS19
- IMS5600MP-DS19
- IMS5400MP-DS19/VAC
- IMS5600MP-DS19/VAC

14 distance values in a measuring range of 2.1 mm



Stable thickness measurement

Stable thickness measurement of a layer

Measuring objects: transparent measuring objects (up to 840 nm)

Models:

- IMS5400-TH45
- IMS5400-TH70
- IMS5400-TH45/VAC

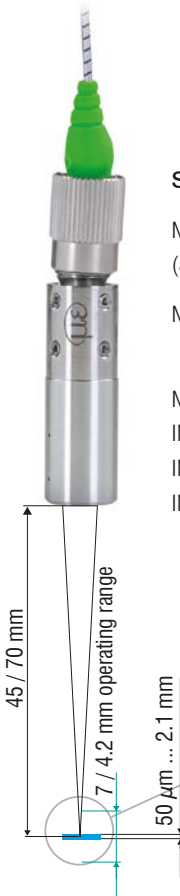

Stable multi-layer thickness measurement

Maximum 5 thickness values of individual layers (and their combinations)

Measuring objects: transparent objects (up to 840 nm)

Models:

- IMS5400MP-TH45
- IMS5400MP-TH70
- IMS5400MP-TH45/VAC

5 thickness values in a measuring range of 2.1 mm

Applications interferoMETER

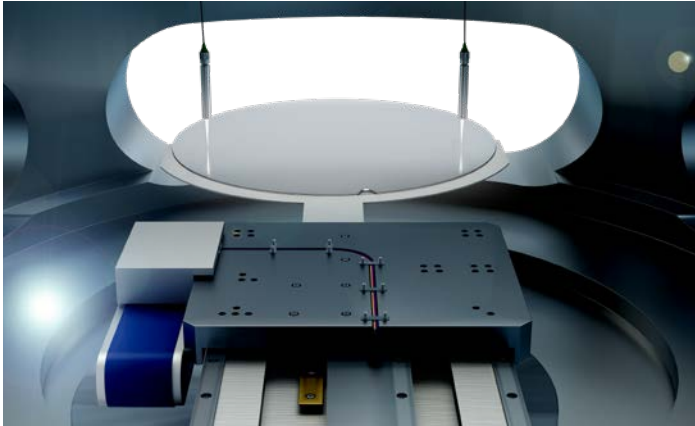

Wafer tilt measurement

White light interferometers are used to measure the horizontal tilt of wafers when wafers are being fed in. The interferometers provide absolute distance values at subnanometer resolution. The measurement ensures the greatest possible positional accuracy when wafers are picked up and removed.

Sensor: *interferoMETER IMS5600-DS19/VAC*

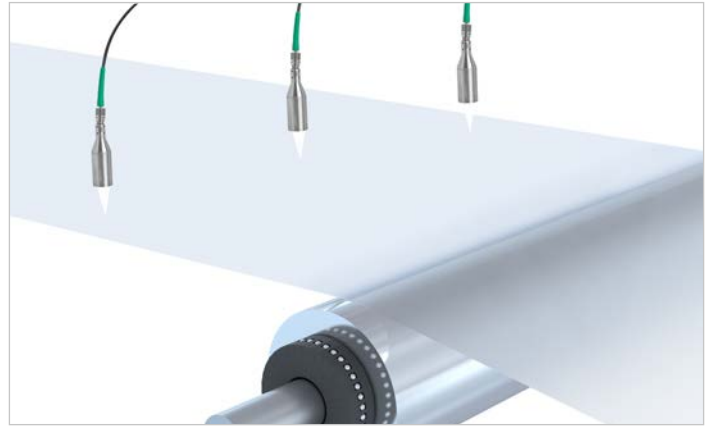

Thickness measurement of plastic films

IMS5400-TH white light interferometers are used for inline thickness monitoring of films. The thickness values are detected with micrometer resolution at a high measuring rate, even if the film flutters slightly.

Sensor: *interferoMETER IMS5400-TH70*

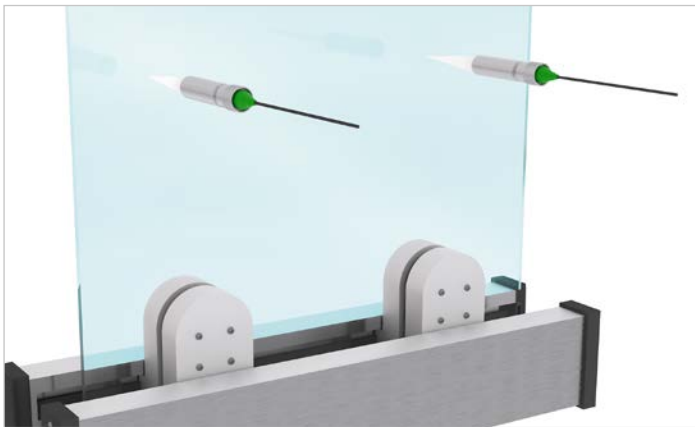

Position measurement when fitting precision glass

In addition to single-peak distance measurements, the white light interferometers are also used for multi-peak distance measurements. This means that both distance values and calculated thickness values can be used to control positioning tasks with maximum precision.

Sensor: *interferoMETER IMS5400MP-DS19*



Multi-layer thickness measurement of display glass

In inline thickness measurements of display glass, the IMS5400-TH white light interferometers impress with their high measurement stability. With the multi-peak thickness measurement, up to 5 layers or air gaps can be measured simultaneously.

Sensor: *interferoMETER IMS5400MP-TH45*

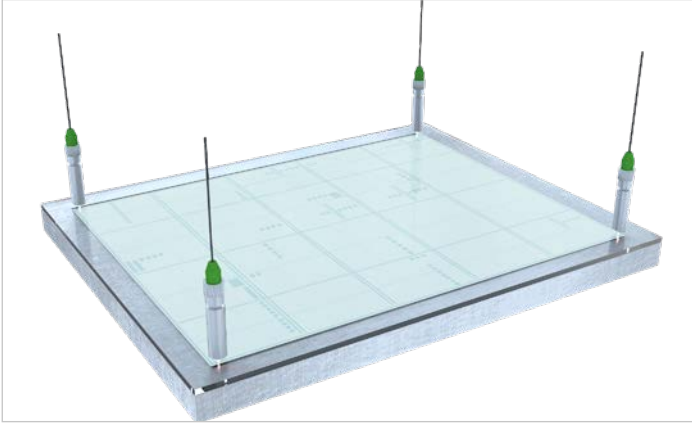

Checking the mask position

White light interferometers are used to align photomasks. The interferometers provide absolute measurement values in the subnanometer range and enable high-precision positioning of the mask. They can also be used in a vacuum.

Sensor: *interferoMETER IMS5600MP-DS19/VAC*

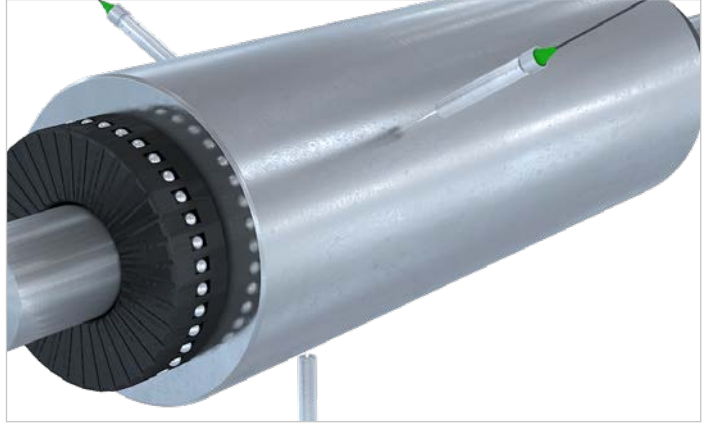

Testing the concentricity of axes

For optical scanning of precision axes, three IMS5400-DS are used to measure onto the rotating part. Thanks to this arrangement, individual tracks can be detected in a short cycle time.

Sensor: *interferoMETER IMS5400-DS19*

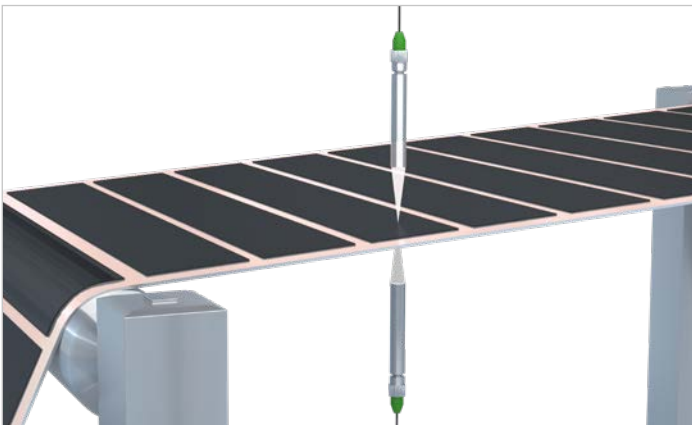

Thickness measurement of electrode coatings

Two opposing white light interferometers measure the thickness of coated electrodes using the differential thickness method. At a constant distance from each other, the two sensors each detect the distance to the film. The white light interferometers enable a measurement resolution in the nanometer range. The thickness values are used to control the application of the coating and for quality assurance purposes.

Sensor: *interferoMETER IMS5400-DS19*

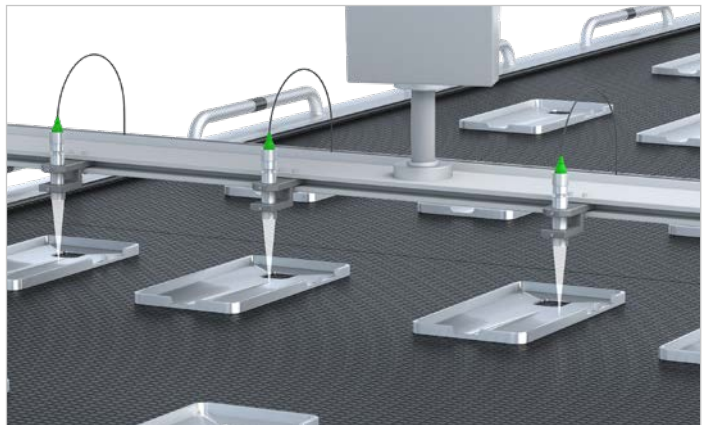







High-precision thickness measurement of transparent layers

IMS5400-TH series white light interferometers are used to inspect the thickness of coatings. Thanks to the large working range, no exact z-positioning is required. The thickness values are detected with micrometer resolution at a high operating range.

Sensor: *interferoMETER IMS5400MP-TH45*

Absolute distance measurement with nanometer resolution

interferoMETER 5400-DS

-  Absolute measurement with nanometer resolution
-  Compact and robust sensors with large offset distance
-  Measuring rate up to 6 kHz for high speed measurements
-  Ethernet / EtherCAT / RS422 / PROFINET / EtherNet/IP
-  Robust controller with passive cooling
-  Easy configuration via web interface



Absolute distance measurements with nanometer resolution

The IMS5400-DS white light interferometer opens up new perspectives in industrial distance measurement. The controller has an intelligent evaluation feature and enables absolute measurements with nanometer resolution at a relatively large offset distance. Compared to other absolute measuring optical systems, the IMS5400-DS offers an unsurpassed combination of accuracy, measuring range and offset distance.

Small light spot for the smallest of details and structures

The sensors generate a small light spot over the entire measuring range. The light spot diameter is only 10 μm and allows the detection of small details such as structures on semiconductors and miniature electronic components.

Absolute measurement of step profiles

Unlike interferometers based on relative measurements, the IMS5400-DS also enables the measurement of step profiles. Thanks to the absolute measurement, the scanning is performed with high signal stability and precision. When measuring on moving objects, the differences in height of heels, steps and depressions can thus be reliably detected.

Multi-peak distance measurement

With multi-peak distance measurement on transparent objects, up to 14 distance values can be evaluated. For example, the distance between the glass and the mask can be determined. If required, the controller can calculate the glass thickness based on the peaks.

 **14 distance values in a measuring range of 2.1 mm**

Multi-peak distance measurement

With multi-peak distance measurement, up to 14 distance values can be evaluated. This allows the distance between the glass and the mask to be determined.



Due to their extremely compact size, these sensors can also be integrated into restricted spaces.

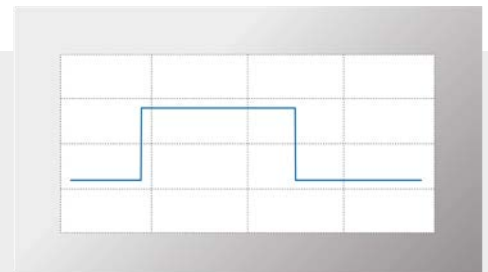

Absolute measurement of step profiles

Due to the absolute thickness measurement, step profiles are detected with high signal stability and subnanometer resolution.

Model		IMS5400-DS19	IMS5400MP-DS19
Measuring range	Distance	2.1 mm	
	Thickness	-	0.010 ... 1.3 mm with BK7
Start of measuring range		approx. 19 mm	
Resolution ¹⁾		< 1 nm	
Measuring rate		continuously adjustable from 100 Hz to 6 kHz	
Linearity ²⁾		< ±50 nm	< ±50 nm for the first distance < ±150 nm for each further distance
Temperature stability	Sensor	Linearity: typ. 0.1 nm / K (without offset displacement)	
	Controller	temperature compensated, stability < 10 ppm between +15 ... +35 °C	
Multi-layer measurement		-	up to 13 layers
Light source		NIR-SLED, wavelength 840 nm Pilot laser: laser LED, wavelength 635 nm	
Laser class		Class 1 according to DIN EN 60825-1: 2015-07 Pilot laser: Class 1, power (< 0.2 mW)	
Light spot diameter ³⁾		10 µm	
Measuring angle ⁴⁾		±2°	
Target material		Glass, reflecting or diffuse surfaces ⁵⁾	
Supply voltage		24 VDC ± 15 %	
Power consumption		approx. 10 W (24 V)	
Signal input		Sync in, trigger in, 2x encoders (A+, A-, B+, B-, index)	
Digital interface		Ethernet / EtherCAT / RS422 / PROFINET ⁶⁾ / EtherNet/IP ⁶⁾	
Analog output		4 ... 20 mA / 0 ... 10 V (16 bit D/A converter)	
Switching output		Error1-Out, Error2-Out	
Digital output		sync out	
Connection	Optical	pluggable optical fiber via E2000 socket (controller) and FC socket (sensor); standard length 3 m, 5 m and 10 m; other cable lengths on request; bending radius: static 30 mm, dynamic 40 mm	
	Electrical	3-pin supply terminal strip; encoder connection (15-pin, HD-sub socket, max. cable length 3 m, 30 m with external encoder supply); RS422 connection socket (9-pin, Sub-D, max. cable length 30 m); 3-pin output terminal strip (max. cable length 30 m); 11-pin I/O terminal strip (max. cable length 30 m); RJ45 socket for Ethernet (out) / EtherCAT (in/out) (max. cable length 100 m)	
Mounting	Sensor	Clamping, mounting adapter (see accessories)	
	Controller	free-standing, DIN rail mounting	
Temperature range	Storage	-20 ... +70 °C	
	Operation	Sensor: +5 ... +70 °C; Controller: +15 ... +35 °C	
Shock (DIN EN 60068-2-27)		15 g / 6 ms in XY axis, 1000 shocks each	
Vibration (DIN EN 60068-2-6)		2 g / 20 ... 500 Hz in XY axis, 10 cycles each	
Protection class (DIN EN 60529)	Sensor	IP65 IP40 (option / VAC)	
	Controller	IP40	
Vacuum		Optional UHV (cable and sensor)	
Material	Sensor	Stainless steel	
	Controller	Aluminum housing, passive cooling	
Control and indicator elements		Multifunction button: two adjustable functions and reset to factory settings after 10 s; web interface for setup: selectable presets, freely selectable averaging, data reduction, setup management; 6 x color LEDs for intensity, range, SLED, pilot laser, status and power; pilot laser: can be switched on for sensor alignment	

All data at constant ambient temperature (24 ± 2 °C)

¹⁾ Measuring rate 0.5 kHz, moving average over 64 values, measured differentially between the front and back of a thin glass plate in the mid of the measuring range (2 sigma)

²⁾ Maximum deviation from reference system over the entire measuring range, measured on front surface of ND filter

³⁾ In the mid of the measuring range

⁴⁾ Maximum sensor tilt angle that produces a usable signal on polished glass (n = 1.5) in the mid of the measuring range.





The accuracy decreases when approaching the limit values.

⁵⁾ Non-transparent materials require optically dense surface at a wavelength of 840 nm

⁶⁾ Optional connection via interface module (see accessories)

Stable thickness measurement with submicrometer resolution

interferoMETER 5400-TH

-  Nanometer-accurate thickness measurement even with varying distances
-  Stable measurement from a long distance
-  Precise thickness measurement of up to 5 layers
-  Measuring rate up to 6 kHz for high speed measurements
-  **INTERFACE** Ethernet / EtherCAT / RS422 / PROFINET / EtherNet/IP



Stable thickness measurement with varying distances

The IMS5400-TH white light interferometer opens up new perspectives in industrial thickness measurement. The interferometer is used for highly accurate thickness measurements from a relatively large distance. The large thickness measuring range allows the measurement of thin layers, flat glass and films. Since the white light interferometer works with an SLED in the near infrared range, it is possible to measure the thickness of optically non-dense objects such as anti-reflective coated glass.

Reliable even with fluttering material

A decisive advantage is the distance-independent measurement, where a stable nanometer-accurate thickness value is achieved. This is how the target can move within the measuring range without influencing the accuracy.

Multi-layer thickness measurement

The thickness of transparent coated objects or laminated glass can be reliably measured thanks to the multi-layer thickness measurement. The controller outputs the thickness values with the highest stability regardless of their position.

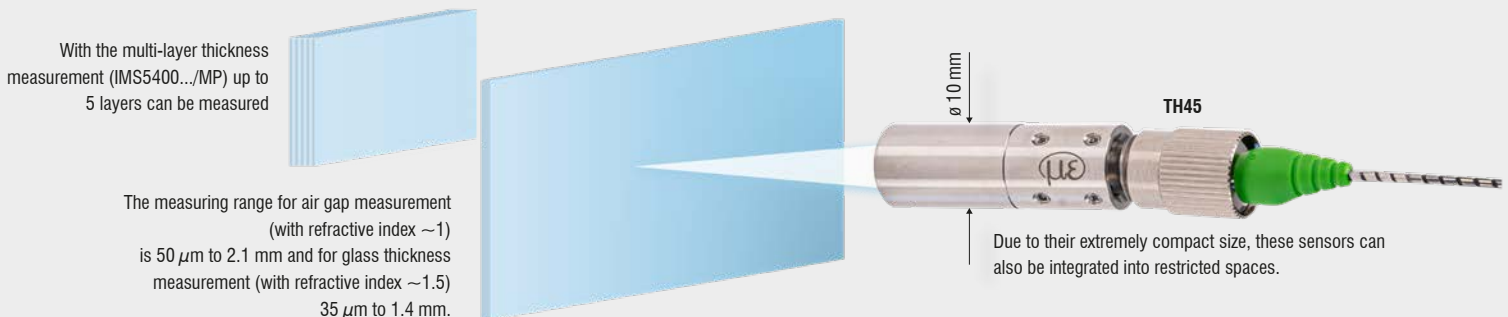

Model	IMS5400-TH45	IMS5400MP-TH45	IMS5400-TH70	IMS5400MP-TH70
Working distance	45 mm ±3.5 mm	45 mm ±3.5 mm	70 mm ±2.1 mm	70 mm ±2.1 mm
Measuring range (thickness)	0.035 ... 1.4 mm ¹⁾			
Resolution ²⁾	< 1 nm			
Measuring rate	continuously adjustable from 100 Hz to 6 kHz			
Linearity ³⁾	< ±100 nm	< ±100 nm	< ±200 nm	< ±200 nm
Temperature stability	Sensor	Linearity valid for the entire temperature range		
	Controller	temperature compensated, stability < 10 ppm between +15 ... +35 °C		
Multi-layer measurement	1 layer	up to 5 layers	1 layer	up to 5 layers
Light source	NIR-SLED, wavelength 840 nm Pilot laser: laser LED, wavelength 635 nm			
Laser class	Class 1 according to DIN-EN 60825-1: 2015-07 Pilot laser: Class 1, power (< 0.2 mW)			
Light spot diameter ⁴⁾	10 μm	10 μm	5 μm	5 μm
Measuring angle ⁵⁾	±2°	±2°	±4°	±4°
Supply voltage	24 VDC ±15 %			
Power consumption	approx. 10 W (24 V)			
Signal input	Sync in, trigger in, 2x encoders (A+, A-, B+, B-, index)			
Digital interface	Ethernet / EtherCAT / RS422 / PROFINET ⁶⁾ / EtherNet/IP ⁶⁾			
Analog output	4 ... 20 mA / 0 ... 10 V (16 bit D/A converter)			
Switching output	Error1-Out, Error2-Out			
Digital output	sync out			
Connection	Optical	pluggable optical fiber via E2000 socket (controller) and FC socket (sensor); standard length 3 m, 5 m and 10 m; other cable lengths on request; bending radius: static 30 mm, dynamic 40 mm		
	Electrical	3-pin supply terminal strip; encoder connection (15-pin, HD-sub socket, max. cable length 3 m, 30 m with external encoder supply); RS422 connection socket (9-pin, Sub-D, max. cable length 30 m); 3-pin output terminal strip (max. cable length 30 m); 11-pin I/O terminal strip (max. cable length 30 m); RJ45 socket for Ethernet (out) / EtherCAT (in/out) (max. cable length 100 m)		
Mounting	Sensor	Clamping, mounting adapter (see accessories)		
	Controller	free-standing, DIN rail mounting		
Temperature range	Storage	-20 ... +70°C		
	Operation	Sensor: +5 ... +70 °C; Controller: +15 ... +35 °C		
Shock (DIN EN 60068-2-27)	15 g / 6 ms in XY axis, 1000 shocks each			
Vibration (DIN EN 60068-2-6)	2 g / 20 ... 500 Hz in XY axis, 10 cycles each			
Protection class (DIN EN 60529)	Sensor	IP65		-
	Controller	IP40 (option / VAC)		-
Vacuum	Optional UHV (cable and sensor)		-	
Material	Sensor	Stainless steel		
	Controller	Aluminum housing, passive cooling		
Control and indicator elements	Multifunction button: two adjustable functions as well as reset to factory settings after 10 s; web interface for setup: selectable presets, freely selectable averaging, data reduction, setup management; 6 x color LEDs for intensity, range, SLED, pilot laser, status and power; pilot laser: switchable for sensor alignment (laser LED 635 nm, laser class 1, power < 0.2 mW)			

All data at constant ambient temperature (24 ± 2 °C)

¹⁾ Measuring range with n=1.5; for air gap measurement between two glass plates (n~1) the measuring range is 0.05 ... 2.1 mm.

The measuring object must be within the working distance.

²⁾ Measuring rate 0.5 kHz, moving averaging over 64 values, measured on an approx. 1 mm thick BK7 optical flat (2 sigma)

³⁾ Maximum thickness deviation when measuring on an approx. 1 mm thick BK7 optical flat (n=1.5) when passing through the measuring range

⁴⁾ With a working distance of 45 mm (TH-45) or 70 mm (TH-70)







⁵⁾ Maximum sensor tilt angle that produces a usable signal on an approx. 0.6 mm thick BK7 optical flat in the mid of the measuring range.

The accuracy decreases when approaching the limit values.

⁶⁾ Optional connection via interface module (see accessories)

Absolute distance measurement with subnanometer resolution

interferoMETER 5600-DS

-  Distance measurement with subnanometer precision
-  Best-in-Class: Resolution < 30 picometers
-  Absolute measurement, suitable for step profiles
-  Compact and robust sensors with large offset distance
-  Measuring rate up to 6 kHz for high speed measurements
-  Ethernet / EtherCAT / RS422 / PROFINET / EtherNet/IP



Designed for high-resolution distance measurements in clean rooms & vacuums

The white light interferometer IMS5600-DS is used for distance measurements with the highest precision. The controller offers a special calibration with intelligent evaluation and enables absolute measurements with subnanometer resolution. The interferometer is used for measurement tasks with the highest accuracy requirements, e.g., in electronics and semiconductor production. For vacuum applications, Micro-Epsilon offers special sensors, cables and feed-through accessories. These sensors and cables are particle-free to a high degree and can even be used in UHV.

Absolute distance measurement with large measuring range and offset distance

The IMS5600-DS is used for high-precision displacement and distance measurements. The system provides absolute measurement values and can therefore also be used for distance measurement of step profiles. Thanks to the absolute measurement, sampling is performed without signal loss. When measuring on moving objects, the differences in height of heels, steps and depressions can thus be reliably detected. The measuring system offers sub-nanometer resolution with a large offset distance in relation to the measuring range.

Multi-peak distance measurement

With multi-peak distance measurement on transparent objects, up to 14 distance values can be evaluated. For example, the distance between the glass and the mask can be determined. If required, the controller can calculate the glass thickness based on the peaks.

 14 distance values in a measuring range of 2.1 mm

Multi-peak distance measurement

With multi-peak distance measurement, up to 14 distance values can be evaluated. This allows the distance between the glass and the mask to be determined.

ø 10 mm

Due to their extremely compact size, these sensors can also be integrated into restricted spaces.

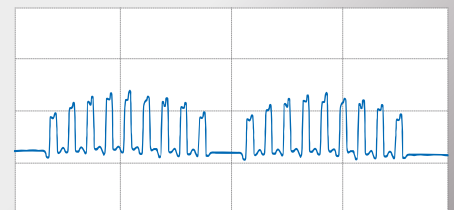

Absolute measurement of step profiles

Due to the absolute thickness measurement, step profiles are detected with high signal stability and subnanometer resolution.

Model		IMS5600-DS19	IMS5600MP-DS19
Measuring range	Distance	2.1 mm	
	Thickness	-	0.010 ... 1.3 mm
Start of measuring range		approx. 19 mm	
Resolution ¹⁾		< 30 pm	
Measuring rate		continuously adjustable from 100 Hz to 6 kHz	
Linearity ²⁾		< ±10 nm	< ±10 nm for the first distance < ±100 nm for each further distance
Temperature stability	Sensor	Linearity: typ. 0.1 nm / K (without offset displacement)	
	Controller	temperature compensated, stability < 10 ppm between +15 ... +35 °C	
Multi-layer measurement		-	up to 13 layers
Light source		NIR-SLED, wavelength 840 nm Pilot laser: laser LED, wavelength 635 nm	
Laser class		Class 1 according to DIN EN 60825-1: 2015-070 Pilot laser: Class 1, power (< 0.2 mW)	
Light spot diameter ³⁾		10 µm	
Measuring angle ⁴⁾		±2°	
Target material		Glass, reflecting or diffuse surfaces ⁵⁾	
Supply voltage		24 VDC ± 15 %	
Power consumption		approx. 10 W (24 V)	
Signal input		Sync in, trigger in, 2x encoders (A+, A-, B+, B-, index)	
Digital interface		Ethernet / EtherCAT / RS422 / PROFINET ⁶⁾ / EtherNet/IP ⁶⁾	
Analog output		4 ... 20 mA / 0 ... 10 V (16 bit D/A converter)	
Switching output		Error1-Out, Error2-Out	
Digital output		sync out	
Connection	Optical	Pluggable optical fiber via E2000 socket (controller) and FC socket (vacuum feedthrough); pluggable UHV optical fiber via FC socket (vacuum feedthrough and sensor); standard lengths 3 m, 5 m and 10 m; other cable lengths on request; bending radius: static 30 mm, dynamic 40 mm	
	Electrical	3-pin supply terminal strip; encoder connection (15-pin, HD-sub socket, max. cable length 3 m, 30 m with external encoder supply); RS422 connection socket (9-pin, Sub-D, max. cable length 30 m); 3-pin output terminal strip (max. cable length 30 m); 11-pin I/O terminal strip (max. cable length 30 m); RJ45 socket for Ethernet (out) / EtherCAT (in/out) (max. cable length 100 m)	
Mounting	Sensor	Clamping, mounting adapter (see accessories)	
	Controller	free-standing, DIN rail mounting	
Temperature range	Storage	-20 ... +70 °C	
	Operation	Sensor: +5 ... +70 °C; Controller: +15 ... +35 °C	
Shock (DIN EN 60068-2-27)		15 g / 6 ms in XY axis, 1000 shocks each	
Vibration (DIN EN 60068-2-6)		2 g / 20 ... 500 Hz in XY axis, 10 cycles each	
Protection class (DIN EN 60529)	Sensor	IP65 IP40 (option / VAC)	
	Controller	IP40	
Vacuum		Optional UHV (cable and sensor)	
Material	Sensor	Stainless steel	
	Controller	Aluminum housing, passive cooling	
Control and indicator elements		Multifunction button: two adjustable functions and reset to factory settings after 10 s; web interface for setup: selectable presets, freely selectable averaging, data reduction, setup management; 6 x color LEDs for intensity, range, SLED, pilot laser, status and power; pilot laser: can be switched on for sensor alignment	

All data at constant ambient temperature (24 ± 2 °C)

¹⁾ Measuring rate 0.5 kHz, moving average over 64 values, measured differentially between the front and back of a thin glass plate in the mid of the measuring range (2 sigma)

²⁾ Maximum deviation from reference system over entire measuring range, measured on front surface of ND filter

³⁾ In the mid of the measuring range

⁴⁾ Maximum sensor tilt angle that produces a usable signal on polished glass (n = 1.5) in the mid of the measuring range.

The accuracy decreases when approaching the limit values.

⁵⁾ Non-transparent materials require optically dense surface at a wavelength of 840 nm

⁶⁾ Optional connection via interface module (see accessories)

Dimensions interferoMETER

IMS5400-DS sensor

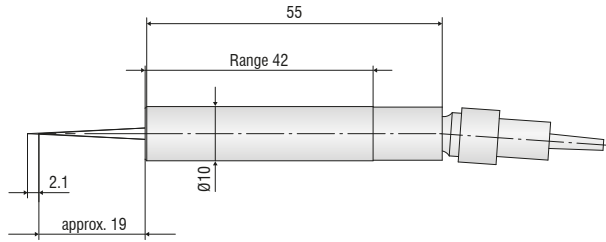

IMS5400-TH45 sensor

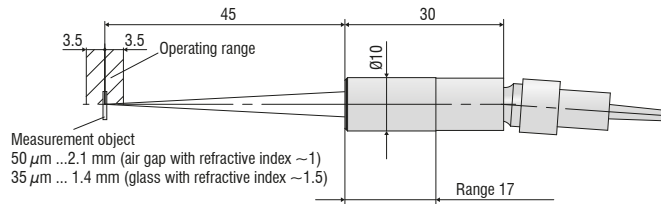

IMS5400-TH70 sensor

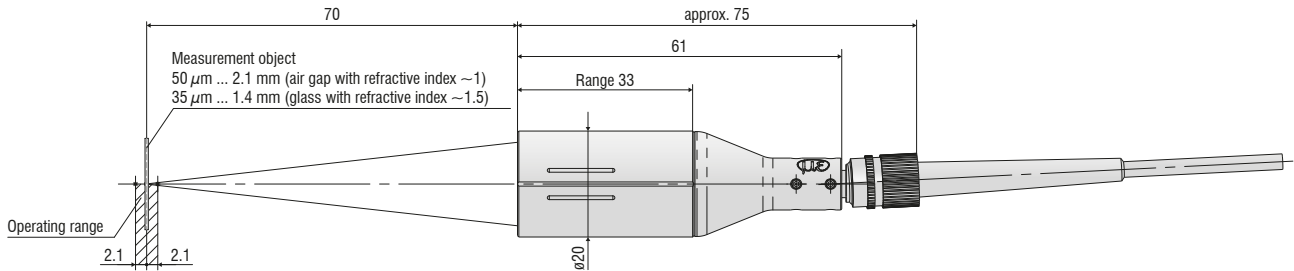

IMS5400-DS / IMS5400-TH / IMS5600-DS controllers

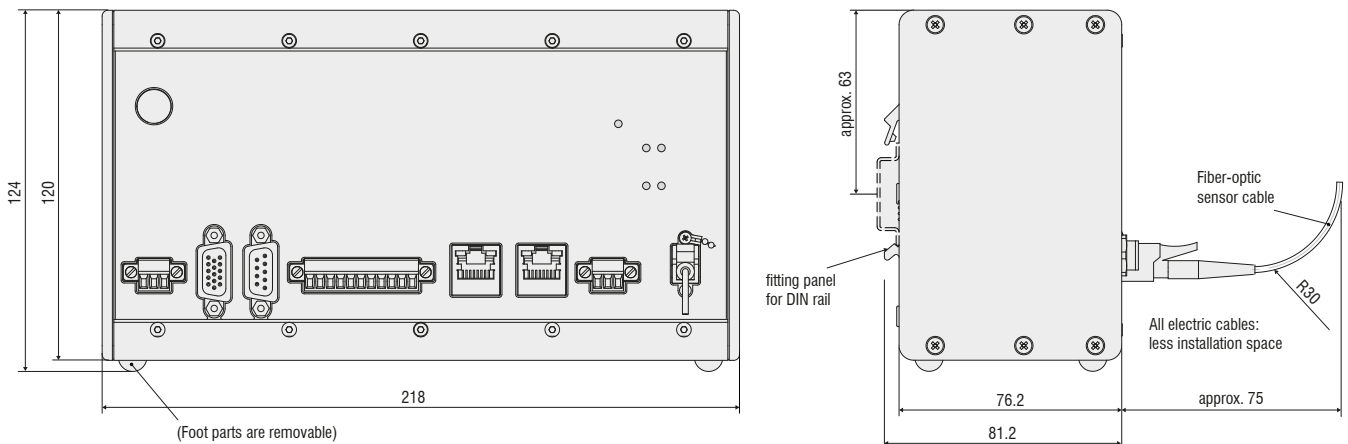

Accessories

interferoMETER

Cables

Standard E2000/APC (controller) and FC/APC connector (sensor)

C5401-2	Optical fiber, length 2 m
C5401-3	Optical fiber, length 3 m
C5401-5	Optical fiber, length 5 m
C5401-10	Optical fiber, length 10 m

Other lengths up to 20 m on request

Drag chain E2000/APC (controller) and FC/APC connector (sensor)

C5401-3(010)	Optical fiber, length 3 m
C5401-5(010)	Optical fiber, length 5 m
C5401-10(010)	Optical fiber, length 10 m

Other lengths up to 20 m on request

Vacuum cable FC/APC connector

C5400-1/VAC	Optical fiber, length 1 m
C5400-2/VAC	Optical fiber, length 2 m
C5400-5/VAC	Optical fiber, length 5 m

Flange for vacuum feed through

C5405/VAC/1/CF16	CF flange
C5405/VAC/1/KF16	KF flange

Mounting Adapter

MA5400- 10	Mounting adapter for IMP-DS19/ -TH45
MA5400- 20	Mounting adapter for IMP-TH70

Other accessories

SC2471-x/IF2008	IMC5400/5600 connector cable+ IF2008/PCIE, length 3 m / 10 m
SC2471-x/RS422/OE	IMC5400/5600 interface cable + IF2001/USB, length 3 m / 10 m
IF2001/USB	RS422/USB converter
IF2008/PCIE	Interface card
IF2030/PNET	Interface module for PROFINET integration
PS2020	Power supply 24V / 2.5A
EC2471-3/OE	Encoder cable, 3 m

E2000/APC standard connector

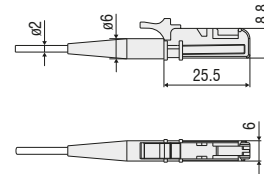

FC/APC standard connector

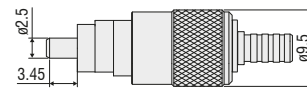

C5405/VAC/1/CF16
C5405/VAC/1/KF16

Accessories interferoMETER

Sensor mounting adapter

For DS19/TH45:
MA5400-10

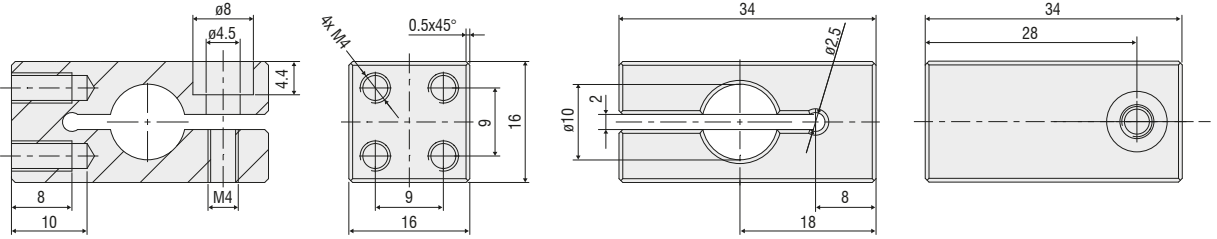

For TH70:
MA5400-20

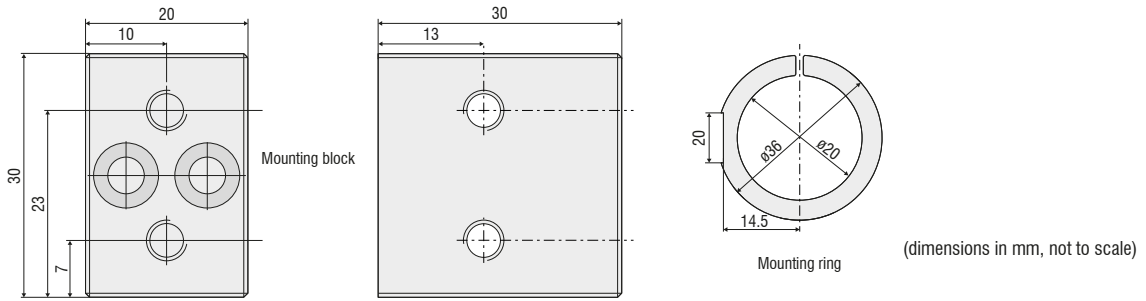

Adjustable mounting adapter

The adjustable JMA mounting adapter simplifies the alignment and fine adjustment of interferometric sensors. You can integrate the sensors with the adapter directly into the machine and then align them directly on site. This corrects, e.g. minor deviations caused by mounting and compensates for tilted measuring objects. With two-sided thickness measurements, the mounting adapter supports the fine alignment of the two measuring points.

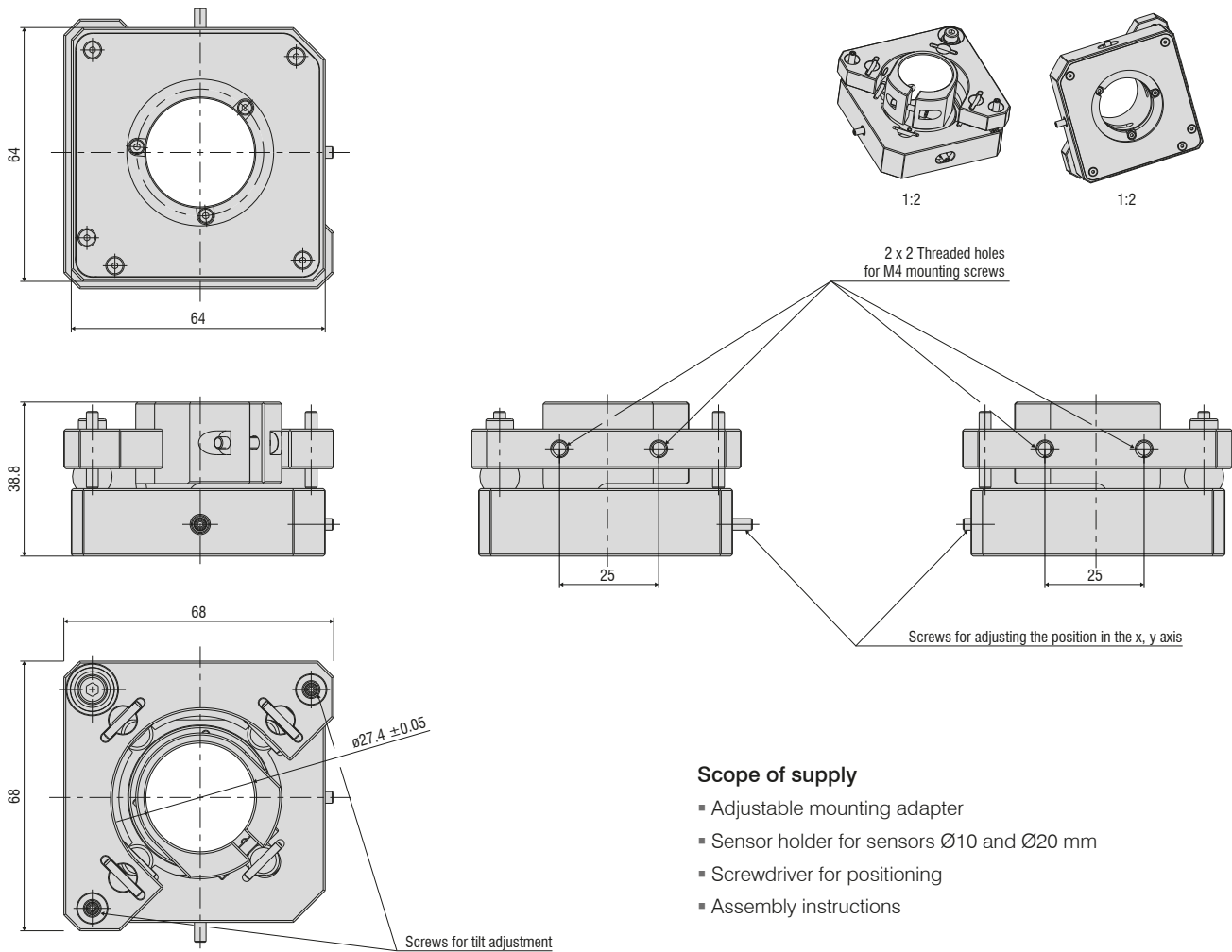

Scope of supply

- Adjustable mounting adapter
- Sensor holder for sensors $\varnothing 10$ and $\varnothing 20$ mm
- Screwdriver for positioning
- Assembly instructions

Sensor holder

Sensor holder for JMA-10

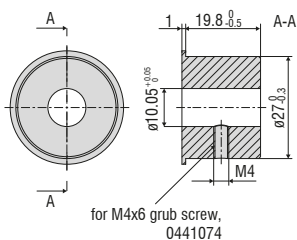

Sensor holder for JMA-20

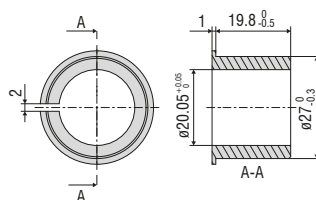

Sensors and Systems from Micro-Epsilon



Sensors and systems for displacement, distance and position



Sensors and measurement devices for non-contact temperature measurement



Measuring and inspection systems for metal strips, plastics and rubber



Optical micrometers and fiber optics, measuring and test amplifiers



Color recognition sensors, LED analyzers and inline color spectrometers



3D measurement technology for dimensional testing and surface inspection